

ITM-6100M

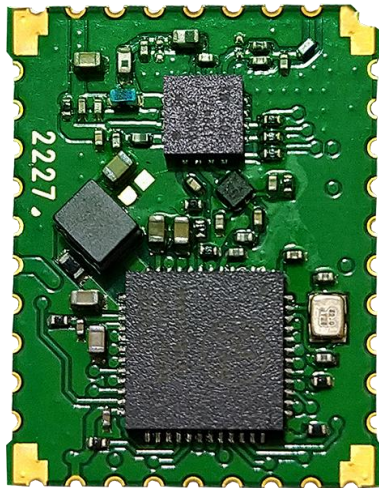

IEEE 802.11ah wireless module

(Preliminary)

V0.3

Revision History

Date	Revision Content	Revised By	Version
2022/07/18	- Initial released (Preliminary)	Marco Liu	0.1
2022/07/19	- Initial released (Preliminary)	Marco Liu	0.2
2022/07/19	- Initial released (Preliminary)	Marco Liu	0.3
	-		
	-		
	-		

Contents

Revision History	2
Contents	3
1. General Description	4
2. Features	5
2.1 ITM-6100M	5
3. General Specification	6
3.1 Voltages	6
3.1.1 Absolute Maximum Ratings	6
3.1.2 Recommended Operating Ratings	6
3.2 Wireless Specification (RX)	6
3.3 Wireless Specification (TX).....	7
3.4 Power Consumption	7
4. Pin Assignments	8
4.1 PCB Pin Outline.....	8
4.2 Pin Definition	9
5. Dimensions	11
5.1 Layout Recommendation.....	11
6. Reference Design	12
7. Recommended Reflow Profile	13

1. General Description

ITM-6100M provides a complete Wi-Fi HaLow connectivity solution. The ITM-6100M module includes Radio, PHY, and MAC sections designed in compliance with the IEEE 802.11ah standard, supporting data rates up to 32.5 Mbps. The standard provides for operation in the sub-1 GHz license exempt RF bands . The Radio in the ITM-6100M supports programmable operation in these bands, worldwide, between 850MHz and 950MHz. The ITM-6100M has been designed for a simplified Wi-Fi HaLow connection to an external host for applications in which a customer wants to merely replace their prior RF technology with a Wi-Fi HaLow connection. The RF receiver features a high linearity LNA, making the use of external filters unnecessary in many applications. Security features required for Wi-Fi HaLow product certifications are supported by ITM-6100M.

The block diagram for ITM-6100M are shown as below.

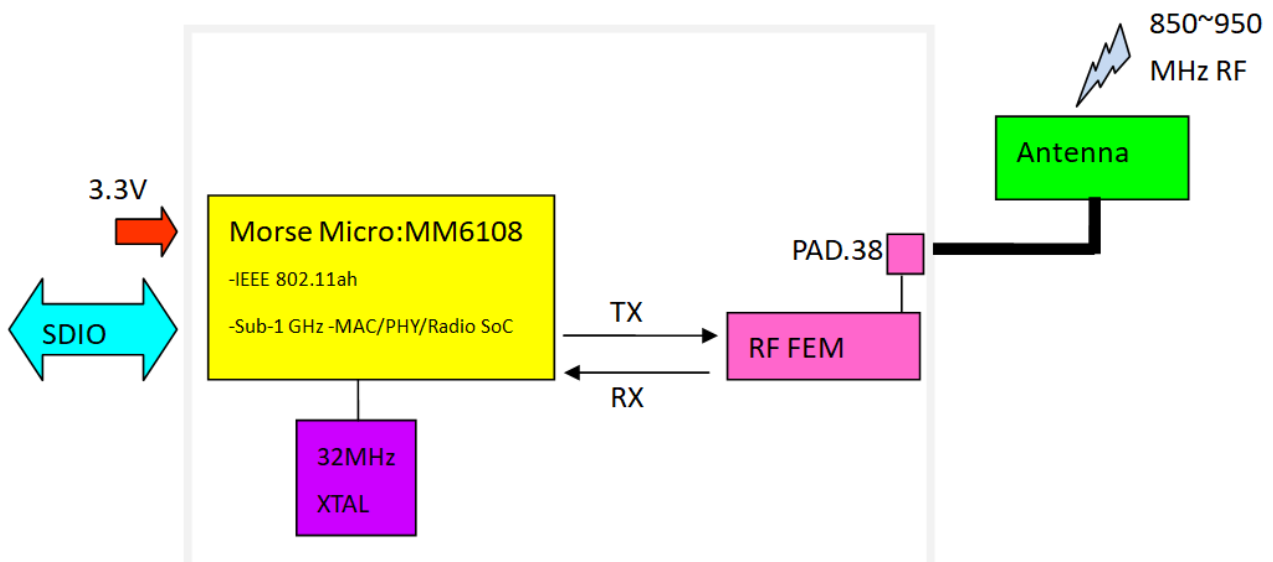

2. Features

2.1 ITM-6100M

- MCU
 - Single Chip Wi-Fi HaLow Transceiver.
 - Single-stream max data rate of 32.5 Mbps.
 - Radio supporting worldwide Sub-1 GHz frequency bands.
 - 802.11ah OFDM PHY supporting future WFA HaLow certification.
 - 802.11ah MAC supporting future WFA HaLow certification.
 - SDIO 2.0 compliant slave interface.
 - Power Management Unit (PMU) for various modes of operation.

- SDIO 2.0 compliant slave interface
 - SDIO 2.0 Default Speed (DS) at 25MHz.
 - SDIO 2.0 High Speed (HS) at 50MHz.
 - Support for both 1-bit and 4-bit data mode.
 - Support for SPI mode operation.

- RF Interface
 - On-chip 8dBm output power, with option to use external PA or FEM.
 - Option to use an external LNA or FEM.

- Wide spectrum of Security features
 - AES encryption engine.
 - Hardware support for SHA1 and SHA2 hash functions (SHA-256, SHA-384, SHA-512).
 - WPA3 including protected management frames (PMF).
 - Opportunistic Wireless Encryption (OWE).

3. General Specification

3.1 Voltages

3.1.1 Absolute Maximum Ratings

ITM-6100M

Symbol	Description	Min.	Max.	Unit
VDD	Input supply Voltage	-0.3	4.2	V
VDD_FEM	Input supply Voltage for RF_FEM	-0.3	4.2	V
VBAT	Input supply Voltage	-0.3	4.2	V

3.1.2 Recommended Operating Ratings

ITM-6100M

Test conditions: At operating temperature 0°C ~ 70°C				
Symbol	Min.	Typ.	Max.	Unit
VDD	3.0	3.3	3.6	V
VDD_FEM	3.0	3.3	3.6	V
VBAT	3.0	3.3	3.6	V

3.2 Wireless Specification (RX)

MCS index	Modulation Scheme	Coding Rate	Phy Rate (kbps) per BW				Estimated Sensitivity (dBm) per BW			
			1MHz	2MHz	4MHz	8MHz	1MHz	2MHz	4MHz	8MHz
0	BPSK	1/2	333	722	1500	3250	-105	-102	-99	-95
1	QPSK	1/2	667	1444	3000	6500	-103	-100	-97	-93
2	QPSK	3/4	1000	2167	3000	9750	-100	-97	-95	-91
3	16-QAM	1/2	1333	2889	4500	13000	-97	-94	-91	-87
4	16-QAM	3/4	2000	4333	9000	19500	-94	-91	-88	-84
5	64-QAM	2/3	2667	5778	12000	26000	-90	-87	-84	-80
6	64-QAM	3/4	3000	6500	13500	29250	-89	-85	-83	-78
7	64-QAM	5/6	3333	7222	15000	32500	-88	-81	-8	-86
10	BPSK	1/2*2	167	N/A			-106	N/A		

3.3 Wireless Specification (TX)

Parameters	Conditions	Min.	Typ.	Max.	Unit
Frequency Range		850		950	MHz
Output power at ANT			27	--	dBm
Total supply current, (transmit mode)	POUT = +27 dBm		280		mA

3.4 Power Consumption

ITM-6100M

Transmit Power consumption:

Mode	Condition TA=25°C, VBAT=VDDIO=3.3V, MCS7	Estimated VBAT Current.	Unit
Transmit Current (0dBm output power, 100% duty cycle)	1MHz channel	48	mA
	2MHz channel	52	mA
	4MHz channel	60	mA
	8MHz channel	74	mA

Receive Power Consumption:

Mode	Condition TA=25°C, VBAT=VDDIO=3.3V, MCS7	Estimated VBAT Current.	Unit
Listen	4MHz channel	37	mA
Active Receive	4MHz channel	40	mA

4. Pin Assignments

4.1 PCB Pin Outline

ITM-6100M (14mm x18mm)

< TOP VIEW >

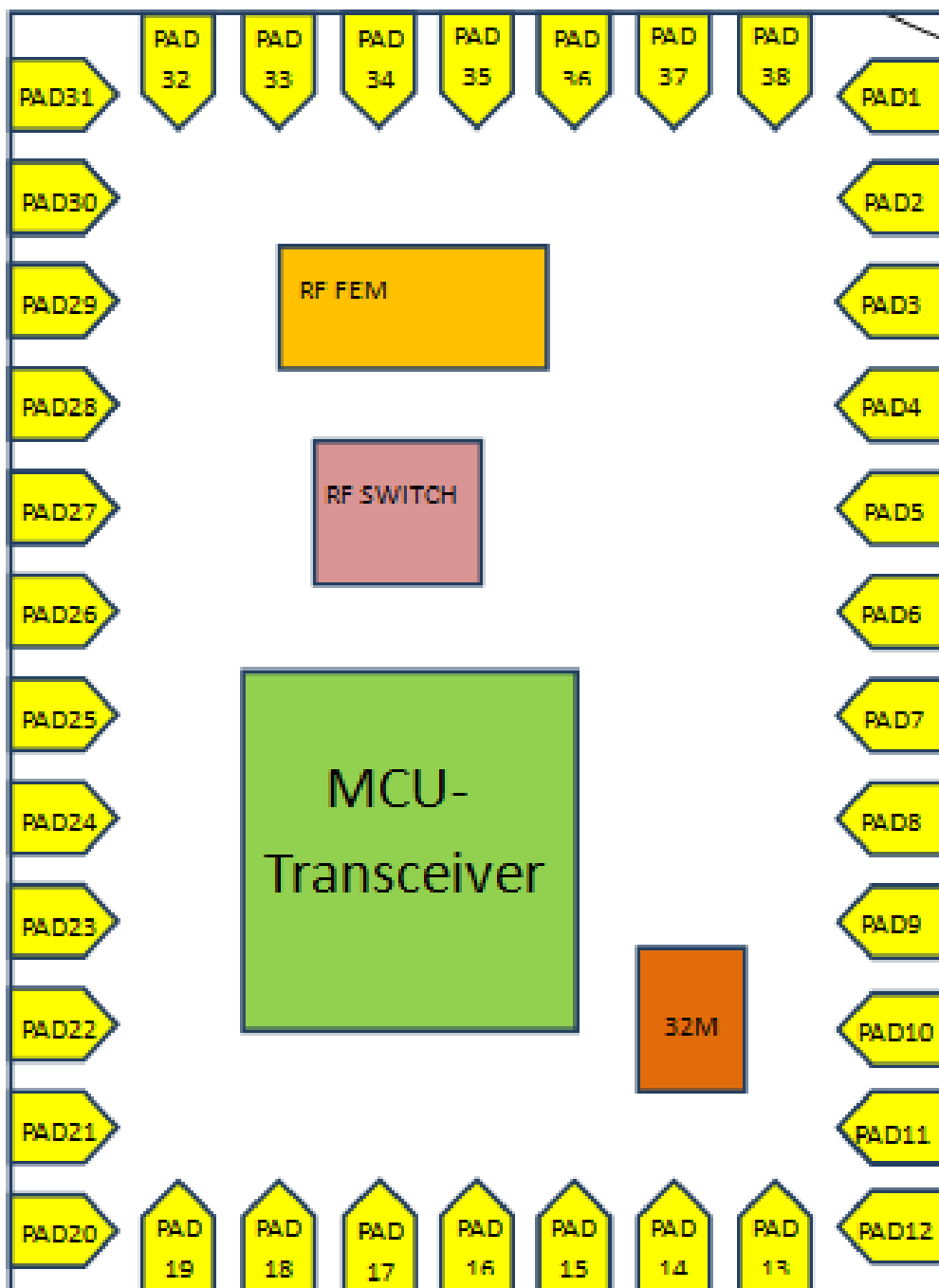

4.2 Pin Definition

ITM-6100M

Pin No.	Pin-Define	Type	Description
1	PAD.1	G	Ground PIN
2	PAD.2	G	Ground PIN
3	PAD.3	G	Ground PIN
4	PAD.4	DIO	MM_JTAG_TCK
5	PAD.5	DIO	MM_JTAG_TDI
6	PAD.6	DIO	NC
7	PAD.7	DIO	MM_JTAG_TMS
.8	PAD.8	DIO	MM_JTAG_TRST
9	PAD.9	DIO	MM_JTAG_TDO
10	PAD.10	DIO	NC
11	PAD.11	DIO	MM_GPIO10
12	PAD.12	G	Ground PIN
13	PAD.13	DIO	MM_GPIO9
14	PAD.14	DIO	MM_GPIO8
15	PAD.15	DIO	MM_GPIO7
16	PAD.16	DIO	MM_SD_D1
17	PAD.17	DIO	MM_SD_D0
18	PAD.18	DIO	MM_SD_CLK
19	PAD.19	P	VDDIO
20	PAD.20	G	Ground PIN
21	PAD.21	DIO	MM_SD_CMD
22	PAD.22	DIO	MM_SD_D3
23	PAD.23	DIO	MM_SD_D2
24	PAD.24	DIO	MM_GPIO6
25	PAD.25	P	VBAT
26	PAD.26	G	Ground PIN
27	PAD.27	DIO	MM_GPIO5
28	PAD.28	DIO	MM_GPIO4
29	PAD.29	DIO	MM_GPIO3
30	PAD.30	DIO	MM_GPIO2

31	PAD.31	G	Ground PIN
32	PAD.32	P	VDD_FEM
33	PAD.33	DIO	MM_GPIO1
34	PAD.34	DIO	MM_GPIO0
35	PAD.35	DIO	MM_RESET_N
36	PAD.36	DIO	MM_WAKE
37	PAD.37	G	Ground PIN
38	PAD.38	RF	RF OUTPUT:ANT1

5. Dimensions

5.1 Layout Recommendation

ITM-6100M

< TOP VIEW >

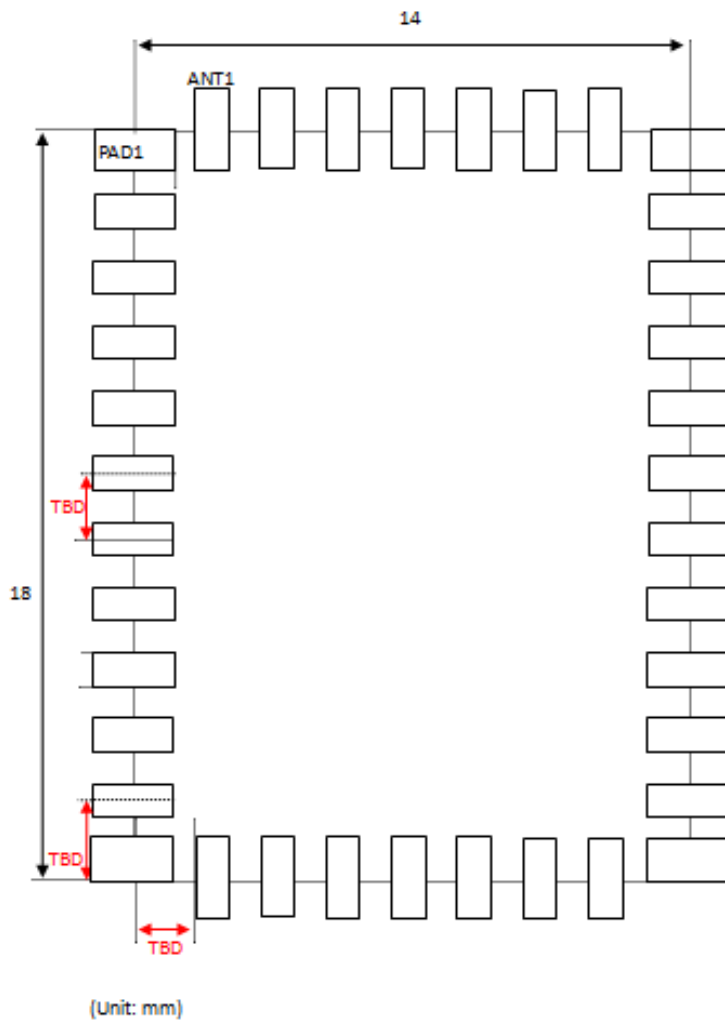

(Unit: mm)

6. Reference Design

ITM-6100M

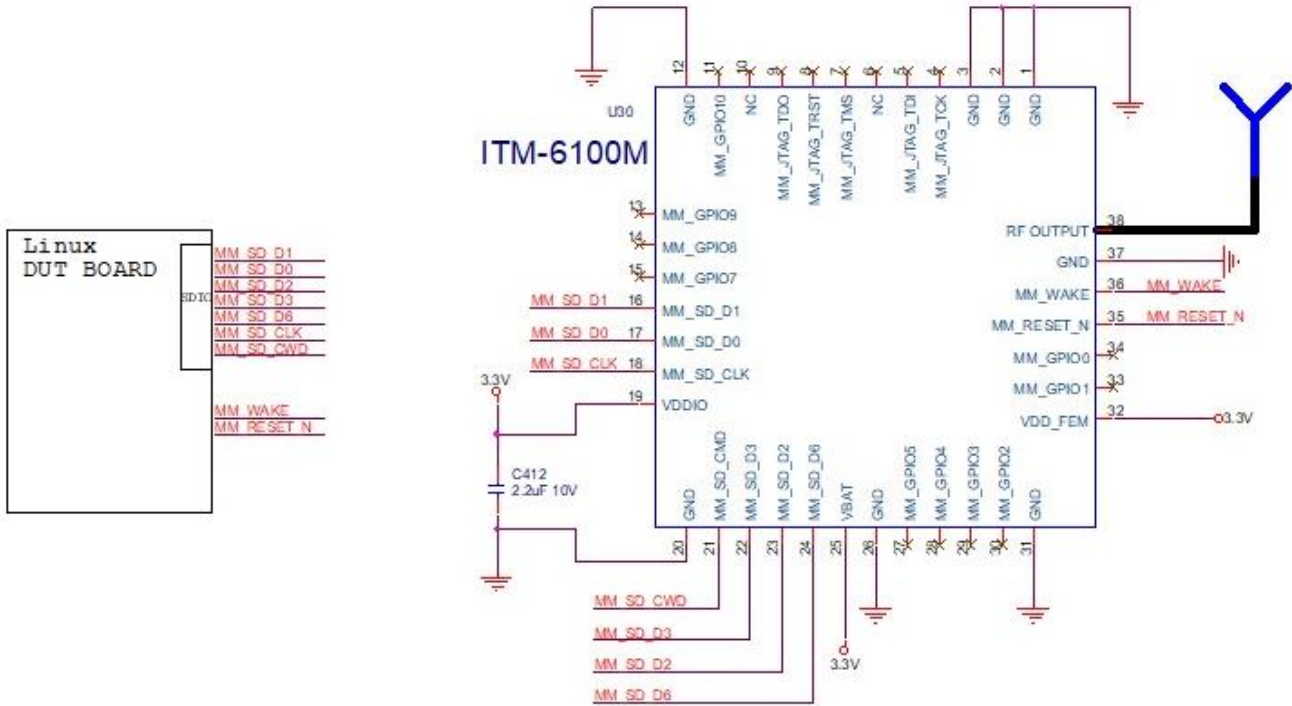

7. Recommended Reflow Profile

Referred to IPC/JEDEC standard.

Peak Temperature : <250°C

Number of Times : ≤2 times

